

11468 \ 24743**TOYOTA PRIUS****1/9/2009**

GROSS LOAD CAPACITY WHEN USED AS A WEIGHT CARRYING HITCH: 2000 LBS. TRAILER WEIGHT & 200 LBS. TONGUE WEIGHT.
*****DO NOT EXCEED VEHICLE MANUFACTURER'S RECOMMENDED TOWING CAPACITY.*****

Parts List			
ITEM	QTY	PART NUMBER	DESCRIPTION
1	4	3/8"	CONICAL TOOTHED WASHER
2	4	M10 - 1.25 x 25	HEX BOLT

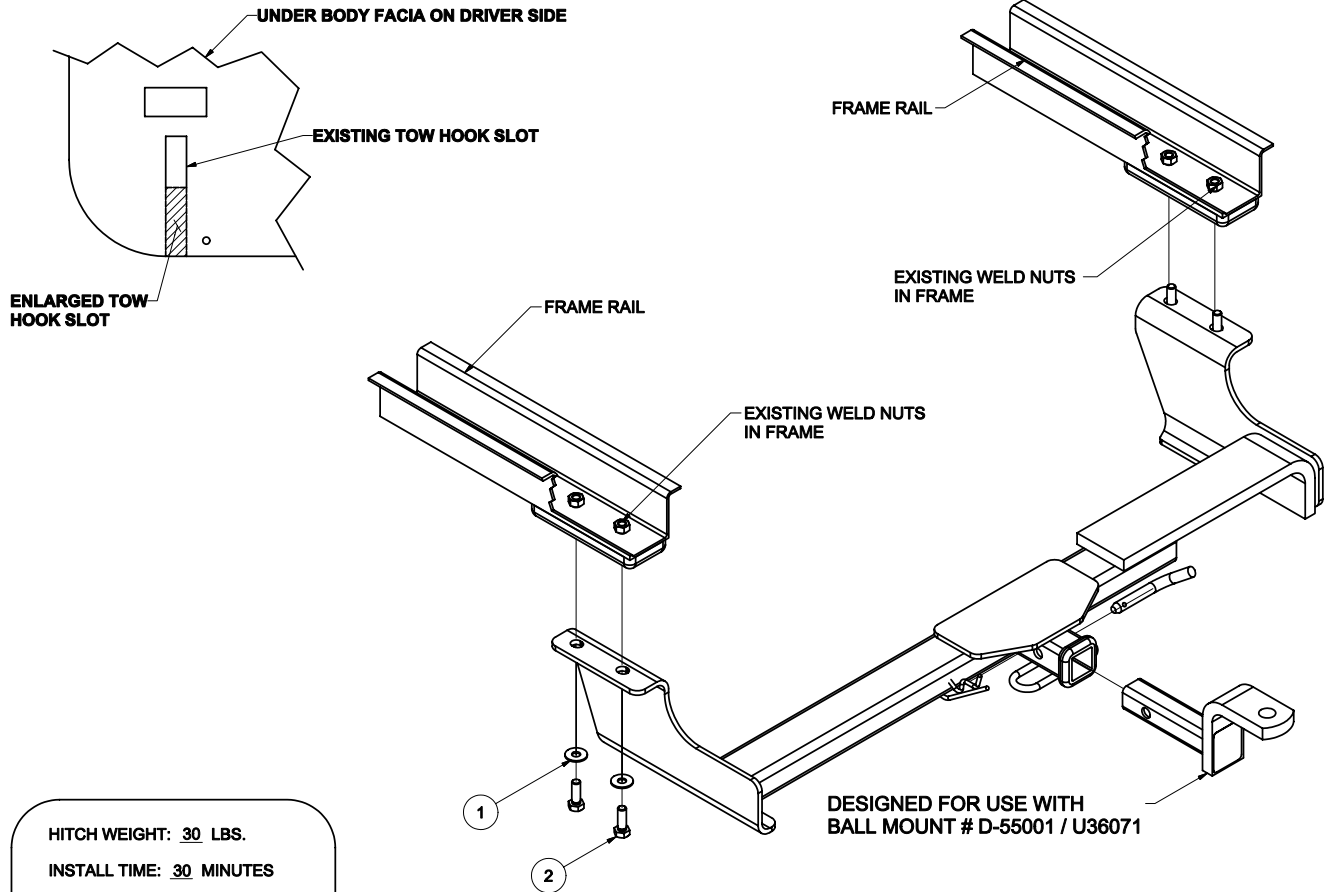

HITCH WEIGHT: 30 LBS.

INSTALL TIME: 30 MINUTES

INSTALL NOTES:
 NO DRILLING REQUIRED
 TRIM UNDER BODY FASCIA

INSTALLATION STEPS

- 1) Remove tow hooks. (Return to customer)
- 2) Remove plastic under body fascia on driver side.
- 3) Lift hitch into position and secure with M10 bolts and conical washers as shown.
- 4) Torque all M10 fasteners to 35 ft-lbs.
- 5) Enlarge tow hook slot on under body fascia to fit around driver side plate as shown.
- 6) Reinstall under body fascia with existing hardware.

PERIODICALLY CHECK THIS RECEIVER HITCH TO ENSURE THAT ALL FASTENERS ARE TIGHT AND THAT ALL STRUCTURAL COMPONENTS ARE SOUND.

Curt Manufacturing Inc., warrants this product to be free of defects in material and/or workmanship at the time of retail purchase by the original purchaser. If the product is found to be defective, Curt Manufacturing Inc., may repair or replace the product, at their option, when the product is returned, prepaid, with proof of purchase. Alteration to, misuse of, or improper installation of this product voids the warranty. Curt Manufacturing Inc.'s liability is limited to repair or replacement of products found to be defective, and specifically excludes liability for incidental or consequential loss or damage.